

BOMAG

FAYAT GROUP

MULTI PURPOSE COMPACTOR BMP 8500

PERFORMANCE DATA

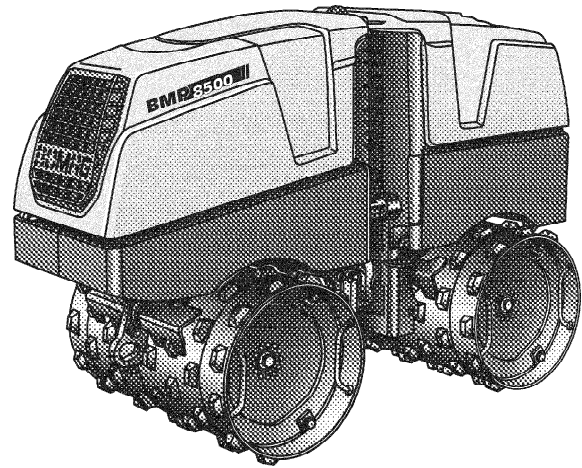

Machine type	Compaction output (m ³ /h) at recommended soil layer thicknesses		
	Gravel, sand	Mixed soil	Silt, clay
BMP 8500	52-82	52-82	30-40

Technical Data

Shipping dimensions in m3

BMP 8500

2,056

Standard

- ECOMODE
- Hydrostatic articulated steering, maintenance free
- Combination remote control cable/radio
- Dual directed-vibration system
- Two travel speed ranges
- 2 amplitudes
- Intelligent Vibration Control (IVC)
- Electric starter
- Hydrost. service brake
- Hydro-mechanical parking brake
- Back-up drive protection
- 2 scrapers per drum
- Battery disconnect switch
- Automatic shutdown at low oil level
- Automatic engine shut down at a lateral tipping angle of > 45°
- Full prot. hoods made of impact resistant compound material
- Single point lifting device
- Lockable engine cover and dash board
- Easy Service Concept
 - Diagnostic module with fault code display
 - Hour meter
 - foldable full protection hood

Options

- Drum extensions (610/850mm)(+48kg)
- Environmentally compliant hydraulic oil
- Special painting
- Mobile quick charger

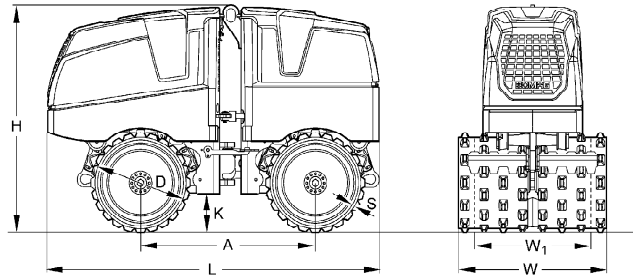

Dimensions in mm

BMP 8500

A	D	H	K	L	S	W	W1
1000	520	1275	222	1897	25	850	610

Technical Data

**BOMAG
BMP 8500**

Weights

Operating weight CECE	kg	1.595
Basic weight	kg	1.585
Average axle load CECE	kg	775

Dimensions

Basic working width	mm	850
---------------------------	----	-----

Driving Characteristics

Speed (1), forward	km/h	1,3
Speed (1), reverse	km/h	1,3
Speed (2), forward	km/h	2,5
Speed (2), reverse	km/h	2,5
Max. gradeability without/with vibr.	%	55/45

Drive

Engine manufacturer	Kubota
Type	D 1005
Cooling	water
Number of cylinders	3
Performance ISO 9249	kW 14,5
Speed	min-1 2.600
Fuel	diesel
Drive system	hydrost.
Driven drum	front + rear

Brakes

Service brake	hydrost.
Parking brake	hydromec.

Exciter system

Vibrating drum	front + rear
Drive system	hydraulic
Frequency	Hz 42
Amplitude	mm 1,12/0,56
Centrifugal force	kN 72/36

Capacities

Fuel	l	24
------------	---	----

Technical modifications reserved. Machines may be shown with options.

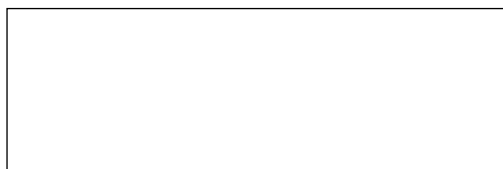

BOMAG
Hellerwald
D-56154 Boppard
P.O. Box 5162
Tel. (0)6742 - 1000
Fax (0)6742 - 3090
Fax (0)6742 - 3090

BOMAG
FAYAT GROUP